



South Australian Dodgeball League

# Rules and Regulations

Written for the South Australian Dodgeball League

Author: Rosie Everett

Version: 1.1

Date Last Updated: May 21, 2022

## Disclaimer

This document was prepared for use by the South Australian Dodgeball League only. All South Australian Dodgeball League documents are periodically reviewed, and new editions are published, between editions, amendments may also be issued. It is the document user's sole responsibility to ensure that the copy of the document it is viewing is the current version including any amendments that may have been issued. Errors or omissions in this document should be reported to the South Australian Dodgeball League.

## Document Updates

Version	Date	Author	Summary of Change
1.0	Apr 8, 2022	Rosie Everett	First issue as a South Australian Dodgeball League document.
1.1	May 21, 2022	Rosie Everett	Clearing up specific changes regarding ball retrievers, etc.

## Contents

<b>INTRODUCTION</b>	<b>7</b>
This Publication	7
Application	7
Nature and Object of Dodgeball	7
Purpose of the Rule Book	7
<b>GENERAL DEFINITIONS</b>	<b>8</b>
<b>ADMINISTRATION REGULATIONS</b>	<b>11</b>
1 Controlling Body	11
1.1 Definition	11
1.2 Application of these Rules	11
1.3 Variations/Exemptions	11
2 The Court	11
2.1 General	11
2.2 Court Surface	11
2.3 Court Dimensions	12
2.4 Areas of Play and Line Markings	12
2.5 Non-Play Areas	12
2.6 Modified Courts	12
3 The Team	12
3.1 Number of Players	12
3.4 Team Sheets	13
3.5 Completing Team Sheets	13
3.5 Uniform	13
3.6 Player Numbers	14
3.7 Footwear	14
3.8 Accessories	14
3.9 Removal and Alterations to Uniforms	14
3.10 Uniform Penalties	14
3.11 Variation to Uniform Penalties	15
4 Equipment	15
4.1 Balls	15
4.2 Suitability for Use	15
4.3 Supply and Selection of Balls	15
5 Scoring	15
6 Match Officials	15
6.1 Main Referee	15
6.2 Line Referee	16
6.3 Conduct of Match Officials	16
7 Misconduct Reviews	16
7.1 Who can report a case of misconduct	16

7.4 How to report a case of misconduct	16
7.5 Who will review cases of misconduct	17
7.6 How cases of misconduct will be investigated	17
<b>MATCH RULES</b>	<b>18</b>
8 The Match	18
8.1 Objective	18
8.2 Winning	18
8.3 Tied Matches	18
8.4 Duration	18
8.5 Stoppages	18
8.6 Timeouts	18
8.7 Cause for Timeout	18
8.8 Timeouts Play Stoppage	18
8.9 Medical Substitution	18
8.10 Timeout Refusal	19
8.11 Variation	19
8.12 Set Duration	19
8.13 End of Half	19
8.14 Actions at End of Half	19
8.15 Intervals Between Sets	19
8.16 Start Warnings	19
8.17 Starting Positions	19
8.18 Starting Signals	20
8.19 Opening Rush	20
8.20 Crossing the Centre Line	20
8.21 Activating Balls	20
8.22 Balls to Retrieve	20
8.23 Retrieving Opposition Balls	21
8.24 Ball Placement	21
8.25 Ball Placement Variation	21
8.26 False Starts	21
8.27 Stopping Play	21
8.28 Expiration of Time	21
8.29 The End of a Set	21
8.30 Throwing After the Set Ends	21
9 Gameplay	21
9.1 Objective	21
9.2 Winning the Set	21
9.3 Valid Throws	22
9.4 Invalid Throws	22
9.5 Striking a Teammate	22

9.6 Deformation of the Ball	22
9.7 Deliberate Invalid Throws	22
9.8 Live Ball	22
9.9 Dead Ball	22
9.10 Dead Players, Objects and Surfaces	23
9.11 Striking Ball	23
9.12 Catching	23
9.13 Blocking	23
9.14 Blocking in Sudden Death	23
9.15 Disarming Ball	23
9.16 Elimination	23
9.17 Strike Elimination	24
9.18 Catch Elimination	24
9.19 Out of Bounds Elimination	24
9.20 Actions Prior to Elimination	24
9.21 Exiting the Court	24
9.22 Revival	24
9.23 Returning to the Court	24
9.24 Fair Pace	24
9.25 Determining the Advantage	25
9.26 Ball Possession	25
9.27 Indicating the Advantage	25
9.28 Advantage Period	25
9.29 Release from the Advantage	25
9.30 Baiting the Advantage	25
9.31 Failing to Throw	25
9.32 Sudden Death	25
9.33 Tie Breaker Set	26
10 Ball Retrieval	26
10.1 Areas of Ball Retrieval	26
10.2 Ball Retrieval Right of Way	26
10.3 Retaining Possession	26
10.4 Incorrect Retrieval	26
10.5 Returning Balls	27
<b>CONDUCT PROVISIONS</b>	<b>27</b>
11 Respect for These Rules	27
11.1 Match Officials Decisions	27
11.2 Ruling Reviews	27
11.3 Honest Conduct	27
11.4 Dishonesty	27
11.5 Maintaining the integrity and spirit of the sport.	27

11.6 Misconduct	27
11.7 Examples of Off Court Misconduct	28
11.8 Complaints of Off Court Misconduct	28
12 Penalties	28
12.1 Penalties for Misconduct	28
12.2 Verbal Warnings	28
12.3 Elimination Through Misconduct	29
12.4 Yellow Cards	29
12.5 Red Cards	29
12.6 Penalty Card Record	29
12.7 Penalty Card Review	29
12.8 Conduct of Team Personnel and Supporters	29
12.9 Penalties for Off Court Misconduct	30
<b>APPENDIXES</b>	<b>30</b>

## **INTRODUCTION**

### **This Publication**

This publication contains the rules of Dodgeball administered and controlled by South Australian Dodgeball League (SADL) adapted from New South Wales Dodgeball's copy via Author Mark Barnsley.

### **Application**

These rules apply to operations affiliated with SADL. The management team may make appropriate modifications consistent with the spirit of these rules for specialised and underaged competitions.

### **Nature and Object of Dodgeball**

Dodgeball is a game played between two Teams competing in accordance with these Rules. The object of each Team is to win the Match by winning more Sets than the opposing team. The winner of the Match is the Team which has scored, in accordance with these Rules, the greater number of Sets at the conclusion of the Match. A Match is drawn when both Teams have the same number of points at the conclusion of the Match.

### **Purpose of the Rule Book**

These Rules explain how a Match of Dodgeball is played and seek to attain the following objectives:

- (a) To ensure that the game of Dodgeball is played in a fair manner and spirit of true sportsmanship; and
- (b) To prevent injuries to players participating in a Match so far as this objective can be reasonably achieved in circumstances where Dodgeball is a physically demanding sport.

## GENERAL DEFINITIONS

Unless the context requires otherwise, the following terms shall have the following meanings:

### **ADC**

Abbreviation for Australian Dodgeball Championship, national level competition.

### **ADF**

Abbreviation for Australian Dodgeball Federation, current Controlling Body for dodgeball in Australia.

### **Advantage**

The Team with the Advantage is required to throw next in the instance that neither Team appears set to throw.

### **ARC**

Abbreviation for Australian Representative Cap.

### **Australian Representative**

A Player who has represented the Australian National Team in the WDBF Championships in the last two (2) years.

### **Ball**

A ball or dodgeball is a foam ball with rubberised skin, used to throw and Eliminate opposition Players.

#### **Dead Ball**

A ball that is no longer a Live Ball and therefore cannot cause Elimination or be Caught;

#### **Inactive Ball**

A ball that has not passed behind an Activation Line since the beginning of the current Set;

#### **Live Ball**

A ball that has been validly thrown which can cause Elimination or be Caught.

### **Ball Retriever**

Person assigned to collect Balls that have left the court for their designated Team.

### **Blocking**

The action of using the Ball in one's hand to deflect an incoming Live Ball.

### **Cap**

The number of allowed Australian Representatives to be registered as a Player to any one Team, or used as a substitution to any one Team.

### **Catch**

Controlling a Live Ball that is thrown by the opposition in order to Eliminate the throwing Player.

### **Club**

An entity fielding Team in a Dodgeball competition conducted by the Controlling Body.

### **Court**

The playing surface used to conduct a Match.

### **Dead Objects, Surfaces or Players**

Anything that is not an active part of the Match with which contact by a Ball will render it a Dead Ball immediately.

### **Disarmed**

A disarm occurs when an opposing Live Ball impacts a Ball held by an Active Player, resulting in the Ball that was struck being dislodged uncontrollably from the Players possession (at the referee's discretion).

### **Division**

Can either be referred to as:



**Gender Division**

A Match with Mixed, Men Only or Women Only Players;

**Tier Division**

A competitive standard, with Division 1 being the highest Division;

**Type Division**

A division separated by rule type. I.e. Cloth and Foam;

**Dodgeball**

A game played between two Teams in accordance with these Rules.

**Elimination**

An Active Player may be Eliminated and as such will no longer participate in the active Set unless revived.

**Extra Time**

Time outside the Regular Time used to complete Sudden Death or Tie Breaker Sets.

**False Start**

Stepping forward off the Base Line prior to the Starting Signal when commencing play in a Set.

**Game**

A Match played during a Round in the SADL season

**Match**

A contest between two Teams to accumulate the greatest number of Sets/points within the specified time and any additional time as prescribed in Match Provisions.

**Match Official**

Any person/s appointed to assist in conducting a match, including but not limited to, a referee, lines person or person performing any duties (paid or unpaid) for or on behalf of the controlling body or SADL.

**MVP**

Abbreviation for Most Valuable Player.

**SADL**

Abbreviation for South Australian Dodgeball League.

**Ordinary Time**

The timed period beginning from the start of the First Half Period, until the specified time limit for the Match has elapsed.

**Player**

A person who plays or is selected to play with a Team or a person who otherwise trains with a Team or who is within the purview of these Rules.

**Active Player**

A Player who is participating in the current Set and has not been Eliminated;

**Eliminated Player**

A Player who is participating in the current Set who has become Eliminated as per these Rules;

**Inactive Player**

A Player who is participating in the current Match but not participating in the current Set.

**Non-Active Player**

A Player who is present but not participating in any Game throughout that Round. This may be due to injury or another reasonable excuse. Non-Active Players are marked as present for attendance records.

**Revival**

Enabling an Eliminated Player from one's Team to return to Active Play by completing a Catch.

**Round**

A SADL day with Matches played across all Divisions.

**Set**

The duration it takes to Eliminate all six (6) Active Players of the opposing Team.

**Sudden Death**

An extra time period with modified rules of game play to expedite completion of a Set.

**Team**

The group of Players competing against another group of Players in a Match of Dodgeball.

**Team Official**

The person/s appointed to assist the Players of the Team/s during a Match, including but not limited to, an officer, coach, assistant coach, trainer, runner, employee or any person performing any duties (paid or unpaid) on behalf of a Club or Team.

**Throw**

Launching a Ball with the intent of Eliminating opposing Players.

**WDBF**

Abbreviation for World Dodgeball Federation.

## ADMINISTRATION REGULATIONS

### 1 Controlling Body

#### 1.1 Definition

A Controlling Body includes:

- (a) SADL and its Officers;
- (b) Any league, association or body responsible for the organisation and conduct of Matches of Dodgeball, who has determined to play such Matches in accordance with these Rules; and
- (c) Any league, association or body responsible for the organisation and conduct of Matches of Dodgeball and which is affiliated with SADL.

#### 1.2 Application of these Rules

These Rules shall apply to all Matches of Dodgeball organised and conducted by a Controlling Body.

#### 1.3 Variations/Exemptions

To provide consistency and a clear pathway toward the peak of the sport, these Rules will be applied as written:

- (a) A Controlling Body may apply to SADL to vary application of these Rules to a competition or competition/s conducted by the Controlling Body;
- (b) Unless specifically allowed under these Rules or a variation allowed by SADL, a Controlling Body should not prescribe any Rules in addition to or conflict with or affect the full operation with these Rules.

## 2 The Court

### 2.1 General

The dimensions and standard marking of the Court are contained in this Section and illustrated in Figure 1.

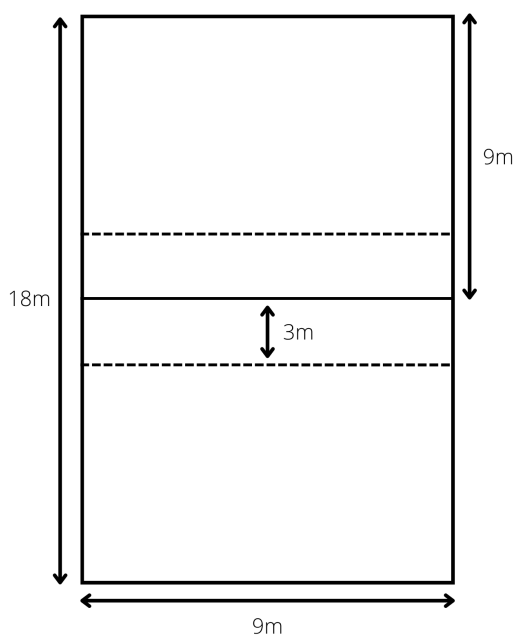

Figure 1. Standard Dodgeball Court

## **2.2 Court Surface**

A Controlling Body may choose to conduct competitions on surfaces they deem suitable. This can vary between timber hardcourt to indoor astroturf.

## **2.3 Court Dimensions**

The court shall be:

- (a) A rectangle;
- (b) 18 meters long;
- (c) 9 meters wide; and
- (d) Divided into two equal half sections by a Centre Line.

Sufficient areas adjacent to the Court should be available for Eliminated, Inactive and Non-Active Players to remove themselves from the Court.

## **2.4 Areas of Play and Line Markings**

The Court boundaries should be marked by lines that are clearly distinguishable from the main surface. Line markings should be 1.5 to 2 inches (38 to 50 millimetres) thick and will include:

- (a) Playable Area: A Team's playable area shall be bounded by the Base Line, Side Lines and Centre Line in their allocated Half Section.

## **2.5 Non-Play Areas**

- (a) Eliminated Player Area

A designated location should be identified at the side of the Court for Eliminated Players to gather a safe distance from play. This is also known as an 'Out Box'. If there isn't a designated area, there will be a 'Next In' mark.

- (b) Centre Line Continuation

The Centre Line, whether marked or not, shall continue beyond the Sidelines separating each Half Sections Non-Play Area.

- (c) Court Adjacent Area

To promote safety, the Controlling Body may designate a/an area/s immediately adjacent the Court for the purpose of restricting non-active participants from that area/s.

## **2.6 Modified Courts**

A Controlling Body may approve altered dimensions for the Court and areas identified in this Section for a modified competition or for standard competition where a complying venue is not readily available.

# **3 The Team**

## **3.1 Number of Players**

A maximum of six (6) Active Players (including a minimum number of two (2) female Players) may be on Court and no more than six (6) Inactive Players. The Controlling Body shall determine the actual number of Players which may play for each Team in the competitions conducted by the Controlling Body. The following regulations cover the player caps, exemptions:

- (a) Number of Players per Division

These player roster caps shall apply to the following divisions:

Division 1 - A maximum of seven (7) players per team roster.

Division 2 - There is no maximum to the player roster, but SADL does recommend a maximum of twelve (12).

- (b) Interstate Player Cap Exemptions  
If a team has a roster that includes an interstate player, they may increase their player roster maximum by one (1) to accommodate that player.

### **3.2 Substitutions**

The following substitution regulations shall apply to the following divisions:

- (a) Division 1 - Substitutions are allowed from Division 2 teams of the same club.  
Division 2 - Substitutions are only allowed for Teams that have less than six (6) registered Players but more than four (4) registered Players in their Team (not including Non-Active Players) for the Round. Substitutions should fill to a maximum of six (6) Active Players and having no Inactive Players. The minimum number of Players must be maintained, i.e., having five (5) males and one (1) female on court is not allowed because the minimum number of two (2) females on court is not maintained.  
All divisions - The Substituting Players must not be registered to another Team in the League outside of their club.
- (b) Player substitutions will only be allowed in between Sets or during Medical Timeouts. A Catch may only revive an Eliminated Player in that Set.
- (c) During finals Matches, no substitutions will be allowed for any Team for any reason, with the exemption of injury, but you may be required to provide a medical certificate.
- (d) Teams with less than four (4) registered Players at finals will be given the option to either:
  - a. Play with the number of Players they have; or
  - b. Forfeit the finals Match.

### **3.3 Additional Supporting Members**

A team is able to have the following additional supporting members in the Non-play / Court Adjacent Area:

- (a) Up to three (3) identifiable Ball Retrievers (See: Ball Retrievers). Bibs will be supplied by the league to assist in identifying Ball Retrievers.
  - a. If bibs aren't available, Ball Retrievers will be requested to identify themselves with other clothing.
- (b) Up to one (1) media officer per team, as long they do not assist in ball retrieval.

All other additional supporting members such as coaches, spectators, non-active players, etc must leave the non-play / court-adjacent area as soon as possible. If an additional supporting member beyond the above limit refuses to leave in a reasonable manner, the team may be penalised.

### **3.4 Forfeits**

A Team is required to have a minimum of four (4) active Players to be deemed not a forfeit. If the Team for any reason does not have the minimum required Players, a forfeit will occur with the Team not maintaining the minimum required Players to lose the Match zero (0) Sets to ten (10) Sets.

### **3.5 Team Sheets**

A Team Sheet shall include:

- (a) The names of the Players in the Team;
- (b) The captain;
- (c) Any Team Officials;
- (d) Date and time;
- (e) Court number;

- (f) Home/away team;
- (g) Main/second/line referees;
- (h) MVP vote;
- (i) Sportsmanship rating;
- (j) Score/final score; and
- (k) Comments/penalties.

### **3.6 Completing Team Sheets**

A Team Official of each Team shall complete the attendance of its players on the Team Sheet and pay its Round fee no later than ten (10) minutes before the scheduled commencement of a team's first Match.

### **3.7 Uniform**

It is mandatory for all Players on a Team to dress alike. The Controlling Body may specify additional uniform requirements suitable for competitions conducted by the Controlling Body.

Team jersey

- (a) Dodgeball jerseys may take any format suitable for vigorous sporting activity and should include the following elements:
  - a. Team colour/s;
  - b. Team logo;
  - c. Player last name – located on back;
  - d. Player number – located as a minimum on back; and
  - e. SADL logo.

May also include:

- (a) Sponsorship logo;
- (b) ADC logo;
- (c) ADF logo;
- (d) Controlling Body logo

### **3.8 Player Numbers**

Player numbers are required to identify and track a player's activity in the Match. Numbers should not be duplicated on the same team. Player numbers are limited to double digits.

### **3.9 Footwear**

Players should wear suitable sporting shoes that provide adequate support to avoid injury. For competitions played on the preferred hard-court surfaces, Players should wear non-marking shoes. Players must adhere to venue rules regarding footwear (and other items). Players without appropriate footwear will be refused entry to the Court and subsequently will not be allowed to participate in the Match as a Player.

### **3.10 Accessories**

Accessories designed to prevent injury are permitted to be worn by Players. Accessories should not significantly detract from, or alter the appearance of the Players uniform. Permitted accessories may include, but are not limited to:

- (a) Knee pads;
- (b) Compression sleeves;
- (c) Joint and limb support; and
- (d) Sweat bands.

Accessories such as hats and gloves are not to be worn on Court during game play. Jewellery such as rings, bracelets and necklaces are advised not to be worn, however, may be worn at a Player's own risk. Match Officials can ask a Player to remove any accessory they deem unfit for game play.

### **3.11 Removal and Alterations to Uniforms**

All uniform items must be worn and are not to be removed during game play. Alterations in any way, shape or form from their original will not be accepted on Court.

### **3.12 Uniform Penalties**

All Teams are to have their respective uniforms ordered and worn by Round 1 of the competition, or in such time as advised by the Controlling Body. A penalty system will be in place for Teams that fail to wear their uniforms by the appointed Round. The penalties include, but are not limited to:

- (a) One (1) Set point loss per item of uniform per person not worn, enforced at the start of the Match;

If Teams do not have their uniform by the specified Round, but have proof of purchase shown to a member of the management team no later than five (5) minutes before their first Match, there will be no penalty.

### **3.13 Variation to Uniform Penalties**

A Controlling Body may determine a varied penalty to uniforms as they see fit.

## **4 Equipment**

### **4.1 Balls**

The official ball of SADL, used in tournament and league play, is a 7-inch (178 millimetre) diameter, rubber-coated, foam dodgeball between 120-160 grams in weight. Any ball over 170 grams in weight is inappropriate for play, as it might inflict bodily harm to the participants of the sport.

### **4.2 Suitability for Use**

Balls shall be considered suitable for use where they:

- (a) Meet the above specifications;
- (b) Retain a reasonable level of their original firmness; and
- (c) Are free from other deformations, including, but not limited to, skin tears.

Players should be aware that Balls may acquire general wear and tear and therefore may require general playing adjustment by the players.

### **4.3 Supply and Selection of Balls**

Unless the Controlling Body decides on an alternative procedure, the following procedure shall apply to the supply and selection of Balls for a Match:

- (a) Six (6) balls per Court shall be supplied by the Controlling Body to the Match Officials;
- (b) A suitable stock of interchangeable Balls shall be made available;
- (c) Match Officials shall inspect and ensure all Balls are suitable for use during the scheduled Matches; and
- (d) Team captains will have the right to request exchange of any Ball that they deem unsuitable for play, but the final decision will be made by the Match Officials.

## 5 Scoring

Match Officials will be responsible for keeping the Match Score, which will determine the outcome. Teams will be awarded one (1) point for each Set they win as outlined within Match Provisions.

## 6 Match Officials

### 6.1 Main Referee

The Main Referee is the person in charge of conducting the Match, making sure the Match runs accordingly and that all Players, Team Officials and Supporters act according to these Rules. They are appointed by the Controlling Body, or volunteers (paid or unpaid) to assist in conducting the Match. The Main Referee will be usually accompanied by another Main Referee to share the duties outlined below, and both referees have an equal weight in decision making.

The Main Referees' role includes, but is not limited to:

- (a) Keeping the official Match Time;
- (b) Keeping the official Match Score;
- (c) Starting, stopping and otherwise controlling the movement of game play;
- (d) Monitoring Player Eliminations, either by Strike, Catch or Out of Bounds;
- (e) Disciplining Players, Team Officials and Supporters accordingly; and
- (f) Keeping a safe and fair environment for Players, Team Officials and Supporters.

### 6.2 Line Referee

A Line Referee is a person who assists in the conducting of a Match who may be appointed by the Controlling Body or volunteer (paid or unpaid).

The Line Referees role includes, but is not limited to:

- (a) Monitoring False Starts; and
- (b) Main Referee roles.

### 6.3 Conduct of Match Officials

Match Officials should act in a fair and unbiased manner towards the Match. Should a Player, Team Official or Supporter feel that the Match Officials are not conducting the Match in a fair and unbiased manner, they may bring the issue up with a member of the management team.

Depending on the nature of the issue, actions taken can include:

- (a) A Verbal Warning issued to the Match Official;
- (b) Disciplinary action, such as removal from the Match.

## 7 Misconduct Reviews

### 7.1 Who can report a case of misconduct

You can report a case of misconduct if you are;

- (a) A captain of one of the teams involved in the game of the case.
- (b) In an instance where the captain was not attending that game, a player can report by proxy and approval of their captain.

The Management Team also have a right to report a case of misconduct if they believe a game has been affected. The Management Team will do so to ensure the league is playing fairly, and will not report a case unless there is a legitimate concern.

### 7.2 You should report a case of misconduct if you are

- (a) Confident of the video evidence;



- (b) Believe the other team has cheated;

### **7.3 Misconduct can be classified as (but not limited to)**

- (a) A player not honouring an elimination (i.e. not taking an out);
- (b) A player re-entering the field of play without a catch occurring;
- (c) An incorrect player intentionally re-entering the field of play upon a catch;
- (d) A player stepping on or over a boundary line, and with full knowledge (i.e. looks at own feet) continues to play on.

### **7.4 How to report a case of misconduct**

As we require evidence of misconduct, you can only submit a review from games that have been recorded and uploaded publicly from South Australian Dodgeball League. These can be found on the Australian Dodgeball Youtube Channel. Only video footage provided by SADL is accepted.

To submit a misconduct report you must email to [southaustraliandodgeballleague@gmail.com](mailto:southaustraliandodgeballleague@gmail.com) the following information;

- (a) Reporter's Full Name
- (b) Reporters Email
- (c) Person(s) involved in misconduct incident's name (If known, otherwise a description is acceptable)
- (d) Video Timestamp(s)
- (e) Description of misconduct incident
- (f) Submit within fourteen (14) days of the video being publicly available.

### **7.5 Who will review cases of misconduct**

The Review Panel will consist of the three (3) members:

- (a) The league owner: Rosie Everett.
- (b) The league manager: Jess Maddeford.
- (c) The referee involved in the match.

In a case that one of the owners is subject to a misconduct review, they will be replaced by either a league manager or the referee that officiated the game.

### **7.6 How cases of misconduct will be investigated**

The Review Panel must have unanimous agreement that there is sound evidence of misconduct for penalties to apply. If there is not a unanimous agreement then the case will not proceed. If a reported case of misconduct is found to not have sufficient evidence and will not proceed, the team that reported will lose the right to report any other cases for the remainder of that season. The panel will scale the penalty based on the player's experience (i.e. As newer players will still be learning the rules, they will not be penalised to the same degree of severity as players of greater experience.)

Advice;

- (a) Ensure that video submissions are clear to you before submitting for review.
- (b) Submit a case only if completely confident of the evidence you are submitting.

### **7.7 Expected penalties for proven cases of misconduct**

Any players found to have a proven case of misconduct will have their team's game result reduced by at least 1 point. Further penalties may apply depending on severity. Some other penalties might be;

- (a) A red card on the player or team;

- (b) A yellow card on the player or team;
- (c) Further point reductions to the game result.
- (d) Player or team disqualification from a Match or Matches;
- (e) Player or team disqualification from a competition or tournament;
- (f) Playing bans; and
- (g) In extreme cases, legal prosecution.

## **7.8 How penalties will be applied and notified**

If there isn't sufficient evidence and the review fails;

- (a) The reporter/captain will be notified by email that their case will not proceed and that they have forfeited any further reports for the remainder of the season.
- (b) The accused teams or players will not be informed.

If there is sufficient evidence and a successful unanimous vote;

- (a) The reporter/captain will be notified by email that their case has proceeded;
- (b) Any penalties to the accused will apply immediately;
- (c) The captain of the accused will be informed of the report and the penalties by email;

(If not already involved in the panel) The Management Team will be informed of the report and the penalties so that they can monitor any penalties that may apply to their league.

## **MATCH RULES**

### **8 The Match**

#### **8.1 Objective**

The objective of a Match is for Teams to win the greatest number of Sets within the allotted time.

#### **8.2 Winning**

The Team with the greatest number of Set wins at the end of the Match will be awarded a Win.

#### **8.3 Tied Matches**

Determined by the Controlling Body conducting the Match, if the final Set of the Match extends beyond expiration of time, such that it enters Sudden Death, and the outcome of that Set ties the score, then the Match may:

- (a) Result in a Tie/Draw; or
- (b) For finals only require a Tie Breaker Set be played to determine a winner.

#### **8.4 Duration**

A Match shall consist of forty (40) minutes of game play, divided into two (2) Half Periods of twenty (20) minutes duration. The 20-minute duration of each Half Period will run continuously from commencement of play to completion of time, with no time stoppages between sets. Match Officials shall keep the official Match Time. This time is considered Ordinary Time.

#### **8.5 Stoppages**

Match Officials have discretion to stop time in the event of major disruption to game play.

#### **8.6 Timeouts**

Each Team will be allowed one (1) Timeouts per Half, which is a total of two (2) per Match. Match Officials will pause match timing for thirty (30) seconds when a Timeout is called. A Timeout may only be called by a Team captain or Team Official.

### **8.7 Cause for Timeout**

A Timeout may be used:

- (a) To discuss a ruling between refs; or
- (b) If a Player on the Court is injured; or
- (c) For another reason, the Team Captain finds suitable, at the discretion of the Match Official.

### **8.8 Timeouts Play Stoppage**

Play will cease immediately upon signal from the Match Official/s that a Timeout is in effect. Any Live Ball thrown prior to the signal shall remain Live and may still Eliminate Players or be Caught with the normal consequences until such it becomes Dead.

### **8.9 Medical Substitution**

Teams may substitute an injured Active Player with:

- (a) An Inactive Player; or
- (b) The next revivable Eliminated Player where no Inactive Player is available.

A Player substituted due to injury cannot return for the rest of the Match or play any remaining Matches within the same Round.

### **8.10 Timeout Refusal**

Match Officials will have discretion to shorten or refuse a Timeout where it is deemed unnecessary to meet reasonable requirements of resolving matters.

### **8.11 Variation**

A Controlling Body may vary:

- (a) The duration of a Match;
- (b) The duration of break intervals;
- (c) The number of Timeouts;
- (d) The duration of Play stoppage; and
- (e) The duration of Match Timing stoppage.

### **8.12 Set Duration**

There is no prescribed limit for the length of a Set. A Set will continue until all Active Players from one Team have been Eliminated.

### **8.13 End of Half**

A Set is to be started if there is any time remaining on the Match Clock. This may mean only 1 second in a set before proceeding to a Sudden Death.

Any Set still in progress when time expires for:

- (a) The First Half Period will continue into the Second Half Period; and
- (b) The Second Half Period or Tie Breaker Set will proceed to Sudden Death.

### **8.14 Actions at End of Half**

Any Balls thrown prior to the signal for expiration of time in either Half Period or a Tie Breaker Set shall remain Live and may still Eliminate players or be Caught with the normal consequences until it becomes Dead.

### 8.15 Intervals Between Sets

Time will continue at the end of each Set. Match Officials will allow thirty (30) seconds from the end of a Set for Teams to take their Starting Positions, at which time the new Set will be started. Teams will be given a warning before the start of the Set.

### 8.16 Start Warnings

To allow Teams to take their starting positions, Teams should be given as a minimum a thirty (30) second warning for the start of the first Set in a Half Period. Should Match Officials determine that both teams are ready sooner, a Set may be started.

### 8.17 Starting Positions

Active Players must take correct Starting Positions for the start of each Set. A Player is in the correct Starting Position when they:

- (a) Are inside the Court; and
- (b) Have at least one (1) foot touching the Base Line.

Any Active Player not inside the Court for the commencement of the Set as signalled by the Match Officials will be Eliminated.

Any Active Player who steps forward off the baseline after the Match Officials have indicated for Teams to be ready but before the Starting Signal is given will be deemed to have False Started.

### 8.18 Starting Signals

Following any required warnings, Match Officials will determine that both teams are ready to begin and invite teams to prepare for commencement.

After a short pause that should be no longer than three (3) seconds, Match Officials will visually check both sides, say 'Ready' whilst simultaneously putting their arm up and then blow a whistle in conjunction with a downward hand movement to initiate the Set, see Figure 2.



*Figure 2: Starting Signal*

Players should move from their Starting Position into the Court immediately upon the whistle. Should Players have their foot/feet on the Base Line for too long, upon Match Officials discretion, that Player may be called Eliminated, as touching any boundary line while in game play results in Elimination.

### 8.19 Opening Rush

Upon the Starting Signal, Active Players may retrieve Balls from the Centre Line to begin play.

### **8.20 Crossing the Centre Line**

Players may cross the Centre Line when retrieving Balls during the Opening Rush, this is the only time this is allowed. There are no requirements to retain contact within the Teams' half of the court. Upon retrieval of the Balls, Players are expected to immediately retreat to their own Court Half, delay may be cause for Elimination at the Match Officials discretion.

### **8.21 Activating Balls**

Balls must be Activated prior to throwing by having them pass behind the Activation Line. Only the Ball will need to pass behind. Until such time as the Ball passes the Activation Line it remains Inactive. If an Inactive Ball is thrown, it immediately becomes a Dead Ball.

### **8.22 Balls to Retrieve**

Teams may initially only retrieve the three (3) Balls on the right of the middle of the Centre Line from their starting end.

### **8.23 Retrieving Opposition Balls**

Balls placed for the Opposition to retrieve may be retrieved after all three (3) of the Team's own Balls have been Activated. After that, the Team may retrieve the opposition Balls, which will require Activation.

### **8.24 Ball Placement**

A Set will begin with six (6) Balls placed on the Centre Line, with three (3) Balls on either side of the middle of the Centre Line, and within a range of 3m from the sidelines. Each Team is responsible for placement of three (3) Balls which they will be allowed to retrieve during the Opening Rush.

### **8.25 Ball Placement Variation**

A Controlling Body may specify the exact location for placement of Balls for the purposes of a Competition conducted by that Controlling Body.

### **8.26 False Starts**

Once Match Officials have indicated for Teams to ready themselves for commencement of the Set, Active Players must remain in the correct Starting Position until the whistle has been blown to initiate the Set. Any Player who moves forward from their Starting Position into the Court prior to the whistle is deemed to have False Started. A False Start will stop play and the Set will be restarted.

Each Team may be issued one (1) warning for a False Start per Half Period. Subsequently, any Player who False Starts within the Half Period may be Eliminated and the Team will restart the Set with one (1) less Player..

### **8.27 Stopping Play**

Match Officials should make all efforts to ensure Players are aware of a Stoppage of Play immediately by blowing the whistle and stepping partially into Court.

### **8.28 Expiration of Time**

Play should stop immediately:

- (a) Upon expiration of Ordinary Time as indicated by Match Officials;; and
- (b) Upon expiration of time allowed for a Tie Breaker Set.

### **8.29 The End of a Set**

Play should stop upon completion of a Set. A Set is complete upon the instant of Elimination of the final Active Player of a Team as indicated by the Match Officials.

### **8.30 Throwing After the Set Ends**

Players should make all efforts to avoid throwing any Balls after the Set has ended. Should a Player deliberately throw a Ball after the Set has ended, it may be considered Misconduct.

## **9 Gameplay**

### **9.1 Objective**

The objective of game play in a Match is to Eliminate all opposing Active Players to win the Set.

### **9.2 Winning the Set**

The first team to validly Eliminate all active players from the opposing team will win the Set and score one (1) point.

### **9.3 Valid Throws**

A Ball must be thrown by an Active Player to become Live. To be deemed to have been thrown, the ball must:

- (a) Initially be controlled in the Players hand/s;
- (b) Leave the Player's hand/s via a launching action; and
- (c) Become airborne.

### **9.4 Invalid Throws**

If a live player throws a ball that is not intended to contribute to that player's team hitting an opposing live player and is not thrown in the general direction of an opposing live player, that player will accrue one warning at the discretion of the referee.

- (a) If that live player accrues more than one warning, they will be Eliminated.
- (b) A live player's accrual of warnings is reset to zero at the end of each set.

Actions that will constitute an invalid throw include, but are not limited to:

- (a) Rolling;
- (b) Kicking;
- (c) Slapping; or
- (d) Scooping; the ball.

### **9.5 Striking a Teammate**

As the objective of throwing is to strike an opponent, a Ball that has been thrown and subsequently contacts a Player from the throwers Team prior to crossing the Centre Line is deemed a Dead Ball.

### **9.6 Deformation of the Ball**

A live player may not excessively pinch, squeeze, compress, or otherwise distort a ball before that player throws that ball or that live player will accrue one warning at the discretion of the referee.

- (a) If that live player accrues more than one warning, they may be rendered out at the discretion of the referee.
- (b) A live player's accrual of warnings is reset to zero at the end of each Match.

### **9.7 Deliberate Invalid Throws**

Balls deemed by Match Officials to have been deliberately thrown:

- (a) Away from opposing Players and Ball Retrievers;
- (b) Off Court; or
- (c) In any other way to waste time,

Will be considered Invalid Throws and will constitute Misconduct.

### **9.8 Live Ball**

As soon as the validly thrown Ball leaves the Players hand, it becomes Live and can cause Elimination of opposing Players or be Caught.

### **9.9 Dead Ball**

A Live Ball remains Live until it becomes Dead when it:

- (a) Contacts a Dead Object, Surface or Player;
- (b) Is Caught; or
- (c) Is deemed Invalidly Thrown

### **9.10 Dead Players, Objects and Surfaces**

Dead Players, Objects and Surfaces are those items that cause the end to a Live Ball's travel, including, but not limited to:

- (a) Non-Active person;
  - i. Eliminated, Inactive and Non-Active Players;
  - ii. Team Officials, Ball Retrievers and Supporters
- (b) The Court Surface, including Line Markings;
- (c) Any surface or structure outside of the Court; and
- (d) Any Ball not in an Active Players physical possession, including those in flight.

### **9.11 Striking Ball**

A Ball that strikes an opposing Active Player continues to be Live until it becomes Dead.

### **9.12 Catching**

Catching a Live Ball validly thrown by an opposing Player before it becomes Dead will:

- (a) Eliminate the thrower; and
- (b) Revive one (1) Eliminated Player from the catcher's Team.

A Catch is completed at the instant the Catching Player:

- (a) Is deemed to have maintained control of the Ball, which can be described as holding the Ball with any part of the catcher's body; and
- (b) Two points of contact the floor within the Court Boundaries.

### **9.13 Blocking**

Players may use the Balls to block an incoming Live Ball. To successfully block, the Player must:

- (a) Retain control over the Ball that is used to block the oncoming Live Ball;
- (b) Retain control over any other Ball the Player may be holding at the time of impact of the Live Ball, regardless of whether it makes contact with the oncoming Live Ball; and
- (c) Avoid any contact by the Live Ball with their person or clothing.

A blocked or deflected Ball remains a Live Ball until it becomes Dead and can cause Elimination or be Caught.

#### **9.14 Blocking in Sudden Death**

Blocking is not available in Sudden Death.

#### **9.15 Disarming Ball**

A blocking Ball that has become dislodged by a Live Ball is neither a Live Ball nor a Dead Ball. The Player or Teammate which has lost control over the blocked Ball must regather control before the Ball becomes Dead to avoid being deemed disarmed.

If the Player or Teammate does regain control over the dislodged Ball, that Player remains an Active Player in the Match. Catching a dislodged Ball does not constitute a Catch towards the Team, and thus does not revive an Eliminated Player.

Should a Player or Teammate fail to regain control over the dislodged Ball, the Player that was in control of the Ball is eliminated by disarm and the Teammate is not Eliminated.

#### **9.16 Elimination**

Active Players who are Eliminated must immediately leave the Court and take a position in the designated area for their Team's Eliminated Players being sure to retain the order in which they were Eliminated. Players are Eliminated by the following:

- (a) Being struck on any part of their person or clothing with a Live Ball, validly thrown by an opposing Active Player, at the instant it becomes Dead without being Caught;
- (b) Validly throwing a Ball which is then Caught by an opposing Player before it becomes Dead;
- (c) Being Disarmed;
- (d) Being Out of Bounds; or
- (e) When directed by Match Officials due to a penalty for Misconduct under Section.

#### **9.17 Strike Elimination**

An Active Player struck on their person or clothing by a Live Ball, validly thrown by an opposing Player will be Eliminated the instant the Ball becomes Dead. A completed Catch does not constitute a Strike.

#### **9.18 Catch Elimination**

An Active Player who validly throws a Ball which is subsequently Caught by an opposing Player will be Eliminated the instant the Catch is completed.

#### **9.19 Out of Bounds Elimination**

Active Players must remain within their Team's playable area. Should an Active Player:

- (a) Step, fall or otherwise touch with any part of their body or clothing; or
- (b) Support themselves with a ball in hand,

On or beyond the Court Boundary for their area, they will be Eliminated the instant they make contact.

#### **9.20 Actions Prior to Elimination**

Any action undertaken in game play prior to the instant of Elimination remains valid.

#### **9.21 Exiting the Court**

An Eliminated Player must leave the Court in a timely manner from the nearest point of exit. If the Player is still holding a/any Ball/s they may pass those Balls to Active Players. Any Ball/s not in their possession which is moved by an Eliminated Player will be surrendered to the opposition.



### **9.22 Revival**

When a Catch is taken, an Eliminated Player from the catching Team is revived and may return to Active Play. If a revived player is exiting the court at the time of revival, they must touch the Eliminated Player Area before returning to court. If no Player is currently Eliminated at the time of the Catch, then no revival will occur.

### **9.23 Returning to the Court**

Before a Revived Player can re-enter the Court, they must touch the Eliminated Player Area with part of their person, then re-enter the Court from the Base Line. Entry from any other area will cause immediate Elimination. Revived Players must re-enter the Court in a timely manner, however, they are not required to do so into immediate threat, such as into the path of a Live Ball in flight; this does not include the threat of a throw. Delaying return unnecessarily may constitute Player Misconduct.

### **9.24 Fair Pace**

To maintain a fair pace, Match Officials will prompt a Team to throw when neither Team appears to be preparing to throw. Match Officials will determine which Team has the Advantage to throw.

### **9.25 Determining the Advantage**

Match Officials will determine which Team has the Advantage by the following:

- (a) The Team with the most Balls will have the Advantage; or
- (b) If both Teams have three (3) Balls, the Team with the most Active Players will have the advantage; or
- (c) If both Teams have three (3) Balls and the same number of Active Players, then the following will determine which has the Advantage:
  - i. At the start of the Match, the Home Team or Team listed first on the fixture will have the Advantage;
  - ii. At the start of a Set during the Match, the Team that won the preceding Set will have the Advantage; or
  - iii. During the Set, the Team that received the last Valid Throw (did not throw last) will have the Advantage.

### **9.26 Ball Possession**

Teams are considered to be in possession of Balls when they are on their side of the Centre Line, even when they are off Court.

### **9.27 Indicating the Advantage**

Match Officials will announce the Team that has the Advantage and indicate by holding out an arm in the direction of the Team's half.

### **9.28 Advantage Period**

The Team will be given ten (10) seconds to make at least one (1) Valid Throw. Match Officials will count the final five (5) seconds aloud.

### **9.29 Release from the Advantage**

Any Valid Throw by the Team with the Advantage or any disposal of a Ball by the opposing Team that crosses the Centre Line, subject to any exception and with consideration of deliberate Invalid Throws will release the Advantage until it is established again.

### **9.30 Baiting the Advantage**

Players may not purposely place or cause the placement of a Ball/s in the opposing Teams half with such proximity to the Centre Line to cause the Advantage to shift and force opposing Players to approach the Centre Line to retrieve the Balls. Balls that, in the natural course of game play, settle in such a location are accepted.

### **9.31 Failing to Throw**

If a Valid Throw is not made or release from the Advantage is not achieved prior to the end of the Advantage Period, the Team with the Advantage will be required to immediately surrender all Balls to the opposition. Until the Balls are handed over, no Elimination can occur.

### **9.32 Sudden Death**

Sudden Death is a game play mode that is devised to hasten the completion of a Set if time has expired. Regardless of the location of Balls at the expiration of time, three (3) Balls will be distributed to each Team to commence Sudden Death. Players may hold the Balls in their hands for the commencement of Sudden Death.

Game Play Alterations:

(a) Blocking

During Sudden Death, any Ball in a Player's possession will be deemed as part of their person. Any Ball blocked will be deemed to have contacted the Player and will cause Strike Elimination if not Caught prior to becoming Dead.

### **9.33 Tie Breaker Set**

During Finals only, a Tie Breaker Set will be played in the instance that the final set of a Match results in a tied score and where a winner must be determined. A Tie Breaker Set will be played for four (4) minutes under normal playing conditions in accordance with these Rules. If the Tie Breaker Set is not completed with the Elimination of one (1) entire team by the expiry of the set duration, Sudden Death will be entered.

## **10 Ball Retrieval**

Teams may employ Non-Active persons as Ball Retrievers; whose role is to retrieve Balls that have left the Court in order to return them to Active Players. Eliminated Players are not permitted to retrieve Balls for their Team, but are able to place or hand to a ball retriever any balls in the Eliminated Player Area.

### **10.1 Areas of Ball Retrieval**

(a) Off Court

Balls may be retrieved by Ball Retrievers once they are wholly and completely beyond the Line of Marked Boundaries.

(b) Centre Line

Balls may be retrieved by Ball Retrievers once they are on or over the Centre Line including its continuation on the side of the Ball Retriever's Team. If a Ball comes to rest on the Centre Line, it may be retrieved by either Team.

(c) Court Surrounds

Ball Retrievers may access all areas adjacent to the Court as is reasonably necessary but may only retrieve Balls.

## **10.2 Ball Retrieval Right of Way**

Ball Retrievers shall have reasonable right of way from other Non-Active persons in performance of their duties, however, Ball Retrievers:

- (a) Must not impede Match Officials in their duty;
- (b) Must not impede any Active Player when retrieving a Ball;
- (c) Must not impede any Ball Retriever from an opposing Team who has a reasonable chance of retrieving a Ball as it approaches the Centre Line; and
- (d) Must take all reasonable precautions to move safely around the Court.

## **10.3 Retaining Possession**

Ball Retrievers may retain possession of Balls until a suitable opportunity to return the Ball to an Active Player arises, so long as no unreasonable delay to the Match occurs.

## **10.4 Incorrect Retrieval**

If a retrieval does not meet the requirements then the Team responsible will forfeit the Ball and be required to pass the Ball as a Dead Ball to the opposing Team.

## **10.5 Returning Balls**

Ball Retrievers may return Balls to Active Players by any reasonable method so long as the action does not:

- (a) Impede active game play in any way;
- (b) Affect the path of travel of any Ball inside the Court;
- (c) Create an Advantage by moving a Dead Ball to benefit any Player/s on Court; and
- (d) Cause unreasonable delay to the Match.

# **CONDUCT PROVISIONS**

## **11 Respect for These Rules**

Respect for the Rules is key to promoting a healthy sport and sporting community.

### **11.1 Match Officials Decisions**

Match Officials are charged with interpreting these Rules and ensuring the Match runs accordingly. During game play, a Match Official's decision is final. Disputing a call may be considered Misconduct.

### **11.2 Ruling Reviews**

Where practical, Players or Teams may seek further explanation or review of a ruling during a Set Break or Timeout, subject to timing restrictions, or after a Match.

### **11.3 Honest Conduct**

While Match Officials are in place, the fast-paced and multi-faceted nature of Dodgeball will often present difficulty for Match Officials in deliberating on every event during game play.

While it is the role of Match Officials to deliberate on the events occurring during game play, in accordance with these rules, Players and Teams participating are expected to act honestly and in cases where Match Officials have not yet ruled, to the best of their ability:

- (a) Rule themselves or Teammates Eliminated when struck;
- (b) Confirm a non-catch when a Ball has not carried the full distance;
- (c) Rule themselves or Teammates Eliminated when having travelled Out of Bounds; and

(d) Otherwise uphold these Rules.

Match Officials will rule on any occurrence where there is dispute over an outcome.

#### **11.4 Dishonesty**

Repeated reports of dishonesty by a Player or Team will be monitored. Any Player or Team found to be acting dishonestly will be considered Misconduct and be subject to a Misconduct Review.

#### **11.5 Maintaining the integrity and spirit of the sport.**

The sport of Dodgeball is fast paced and competitive, however, Players and Teams participating are expected to conduct themselves in a manner that upholds the integrity of the sport and fosters the spirit of the sporting community.

#### **11.6 Misconduct**

Misconduct detracts from the spirit of the sport and will not be tolerated. Any action that brings the game in disrepute may be considered Misconduct. Misconduct will include, but not be limited to:

- (a) Poor sportsmanship, such as:
  - i. Disrespectful actions or aspersions towards Players, Official or Supporters; or
  - ii. Refusal to follow protocol; or
  - iii. Self-referring or calling opponents out;
- (b) Fighting, assault or unnecessary roughness such as:
  - i. Intentional hard striking at close range;
  - ii. Intentional striking after Elimination; or
  - iii. Impeding an opposition Player's space near or beyond the Centre Line;
- (c) Vilification of any kind;
- (d) Generally offensive behaviour such as excessive use of foul language;
- (e) Mistreatment of equipment, such as:
  - i. Kicking or spiking Balls; or
  - ii. Squeezing or crumping Balls;
- (f) Dishonesty in the case of Elimination not identified by Match Officials; and
- (g) Interference in game play proceedings by any Non-Active person.

#### **11.7 Examples of Off Court Misconduct**

The following are examples of off Court Misconduct include, but are not limited to:

- (a) Causing unreasonable delay to the Match by any action;
- (b) Any action aimed at distracting Players or Officials, such as loud or abrupt noises;
- (c) Offensive comments or gestures;
- (d) Unnecessary physical contact with Players, Officials or Supporters;
- (e) Inactive or Non-Active Players, Team Officials or Supporters entering the Court; and
- (f) Providing unfair or undue assistance to Active Players, such as supporting a Player's balance or providing leverage during the Opening Rush.

#### **11.8 Complaints of Off Court Misconduct**

A lead Team Official or Team Captain may approach Match Officials during a Set Break to request they monitor the off-Court conduct of opposing Team Officials, Support Staff, other Non-Active participants and Spectators. Match Officials may issue warnings or penalties at their discretion.

## **12 Penalties**

### **12.1 Penalties for Misconduct**

Instances of Misconduct will result in penalties to be prescribed by Match Officials. These may include, but are not limited to:

- (a) A red card on the player or team;
- (b) A yellow card on the player or team;
- (c) Further point reductions to the game result.
- (d) Player or team disqualification from a Match or Matches;
- (e) Player or team disqualification from a competition or tournament;
- (f) Playing bans; and
- (g) In extreme cases, legal prosecution.

### **12.2 Verbal Warnings**

When appropriate, Players should be given the opportunity to reconsider any part of action that tends towards Misconduct. Verbal Warnings will be given by Match Officials when a single instance of an infraction does not seem to warrant a penalty. Repeated behaviour following a Verbal Warning will incur further penalties such as Elimination or Penalty Cards. Match Officials will determine the appropriate follow up penalty.

### **12.3 Elimination Through Misconduct**

Players may be Eliminated by Match Officials when Misconduct unfairly influences game play outcomes. This penalty should be used in low level competition only with preference for use of Penalty Cards at higher level competitions.

### **12.4 Yellow Cards**

Yellow Cards may be issued by Match Officials to:

- (a) Active Players – when on Court Misconduct occurs. Yellow Cards issued to individual Players will be recorded against that player's Team; and
- (b) Teams – when off Court Misconduct by any person connected with that Team occurs.

A Yellow Card is the next disciplinary level after a Verbal Warning to penalties for Players and Teams. A single Yellow Card infraction will have the following consequences:

- (a) An individual Player that receives a Yellow Card is immediately disqualified from participating in the remainder of that Set, and the next Set;
- (b) The Team is required to compete with only five (5) Active Players;

A second Yellow Card infraction to either a Player or Team will have the same consequences as a Red Card.

### **12.5 Red Cards**

Red Cards may be issued by Match Officials to a Player or Team:

- (a) As a second offence to a Yellow Card infraction; or
- (b) In a case of serious Misconduct without warning.

A Red Card is the disciplinary level after Yellow Cards to penalties for Players and Teams. A single Red Card infraction will have the following consequences:

- (a) An individual Player that receives a Red Card is immediately disqualified from participating in the remainder of that Match, and the next Match;
- (b) The Team is required to compete with only five (5) Active Players;

## **12.6 Penalty Card Record**

A record of Penalty Cards issued should be kept by Match Officials and reported to the Controlling Body conducting the competition at the end of the Match. This record should be made available for Players and Teams.

## **12.7 Penalty Card Review**

Cards issued by Match Officials during a Match will stand until the completion of that Match. Teams and Players may request a review from the Controlling Body conducting the competition following completion of the Match. Any review will not affect the recorded outcome of a Match and can only alter the record of Penalty Cards issued.

## **12.8 Conduct of Team Personnel and Supporters**

Teams are accountable for the actions of Team Officials, Support Staff, other Non-Active participants and to a reasonable degree; Spectators supporting the Team. Poor conduct from these groups may constitute Misconduct and result in the issuing of a penalty to either the related Team or the perpetrating individual.

## **12.9 Penalties for Off Court Misconduct**

Teams for whom supporting Support Personnel or Spectators have been found to be in breach of conduct requirements may be subject to any penalty at the discretion of Match Officials.

# **APPENDIXES**

## **13 Example Interpretations**

### *Blocking Example 1*

Player A is holding three (3) Balls, one in each hand and a third trapped between the other two (2). Player A attempts to block an incoming Live Ball with the Ball in their right hand, but in doing so drops the third Ball that was trapped. Even though the third Ball was not apparently hit by the Live Ball, the Ball was dropped concurrently with and due to the impact of the Live Ball and Player A is Eliminated.

### *Blocking Example 2*

Player A is holding three (3) Balls when opposing Player B throws a Live Ball. Player A clearly drops one (1) Ball before using the remaining two (2) to block Player B's Live Ball. Since Player A did not drop the Ball due to the impact of the Live Ball, Player A is not Eliminated.

### *Blocking Example 3*

Player A is holding two (2) Balls and uses one (1) Ball to block an incoming Live Ball. The Ball used to block the Live Ball was held out in front of Player A's face while Player A dropped the Ball they were holding at their side at the time of impact. Since the dropped Ball was not clearly a result of the impact of the Live Ball which was blocked, Player A is not Eliminated.

### *Complex Example 1*

Two (2) Live Balls are thrown at Player A. The first Ball strikes and bounces in the air while the second Ball is caught before the first Ball hits the ground. The Catch is deemed Valid; however, Player A is still Eliminated the instant the first Ball becomes Dead.

#### *Complex Example 2*

Player A throws a Ball at Player B, but right before the Ball hits Player B, Player B throws a Ball at Player A. Both Balls thrown are Live Balls and both Players are Eliminated if Player A got hit by Player B's Ball. This is often called a 'Double Elimination'.

#### *Complex Example 3*

If Player A and B are the last Players remaining (i.e., there is a one-on-one) and there is a 'Double Elimination', the set shall be awarded to the Team whose last Player was Eliminated second, keeping in mind that a Player is not Eliminated until the Ball that struck them becomes Dead. If Player A's Ball hit Player B before Player B's Ball hit Player A, but Player B's Ball hits the ground before Player A's Ball, Player A is Eliminated first and Player B's Team is awarded the Set.

#### *Complex Example 4*

Player A is hit by a Live Ball which bounces high into the air. Player A throws a Ball at Player B while the that hit Player A is still in the air (i.e., before becoming Dead). The Ball thrown by Player A is still a Live Ball capable of Eliminating Player B or being Caught.

#### *Ricochet Example 1*

If Player A throws a Live Ball which strikes opposing Player B and ricochets to also strike opposing Player C before becoming Dead, then both opposing Players B and C are Eliminated.

#### *Ricochet Example 2*

If Player A throws a Live Ball which is blocked by opposing Player B and then strikes opposing Player C before becoming Dead, then Player C will be Eliminated.

#### *Ricochet Example 3*

If a Live Ball ricochets off a Dead Player exiting the Court and hits another Player, the Ball is deemed a Dead Ball and the hit does not cause another Elimination.

#### *Complex Ricochet Example*

If Player A throws a Live Ball which is blocked by opposing Player B and then hits Player C on the throwing team (Player A's team) while still a Live Ball, Player C is not Eliminated, but the Ball is still a Live Ball which may yet be Caught by the opposing Team until it becomes Dead.

#### *Dead Ball Example*

Player A is struck by Live Ball 1. Player A throws Live Ball 2 which strikes Player B on the opposing Team prior to Live Ball 1 becoming Dead, making the throw Valid. Live Ball 2 then also becomes Dead. Player A and Player B are Eliminated.

#### *Out of Bounds Example 1*

Player A releases Live Ball 1 in a Valid Throw before stepping on or beyond one of the Boundary Lines. Live Ball 1 strikes opposing Player B and becomes Dead. Player A is Eliminated the instant they make contact Out of Bounds but the throw released prior is Valid. Player B is Eliminated.

#### *Out of Bounds Example 2*

Player A releases Live Ball 1 in a valid throw immediately after stepping on or beyond one of the Boundary Lines. Live Ball 1 strikes opposing Player B and becomes Dead. Player A is Eliminated the instant they make contact Out of Bounds so the throw released after is Invalid. Player B is not Eliminated.

#### *Catching Example 1*

If Player A attempts to Catch a Live Ball and loses balance and falls/lands Out of Bounds before Player A has complete control of the Ball, such as still juggling the Ball, then it is not deemed a Catch and Player A is Eliminated.

#### *Catching Example 2*

If Player A attempts to catch a Live Ball and is hit by a Live Ball thrown by opposing Player B which becomes Dead before Player A has complete control of the Ball, such as still juggling the Ball, then it is not deemed a Catch and Player A is Eliminated.

#### *Catching Example 3*

Player A throws a Ball which strikes opposing Player B and then ricochets and is Caught by another opposing Player C before becoming Dead. The Catch is Valid. Player A is Eliminated as their throw was Caught. Player B is not Eliminated. This is often known as a 'Team Catch'.

#### *Catching Example 4*

Player A throws a Ball which is blocked by opposing Player B and then ricochets and is Caught by another opposing Player C before becoming Dead. The Catch is Valid. Player A is Eliminated as their throw was Caught.

#### *Catching Example 5*

Player A throws Live Ball 1. Opposing Player B then throws Live Ball 2 which strikes Player A and becomes Dead. After Live Ball 2 becomes Dead, opposing Player C (Player B's Team) catches Live Ball 1. As Live Ball 1 was Live, the Catch is Valid despite Player A being Eliminated before the Catch was completed.

#### *Catching Example 6*

If Player A throws a Ball at opposing Player B which is blocked or ricochets and is Caught by Player A's team while it is still a Live Ball, this does not constitute a Catch.

#### *Revival Example*

Player A is revived and returns via the Side Line rather than the Base Line. Opposing Player B throws a Ball which strikes Player A and becomes Dead. Regardless of the decision on the incorrect re-entry, Player A is Eliminated.

#### *Elimination Example*

If Player A is struck and leaves the Court while the striking Ball is still Live, Player A is Eliminated for being Out of Bounds. If the striking Ball is Caught before it becomes dead, Player A remains Eliminated but is eligible for Revival subject to the order of Elimination, i.e., if Player A is the only Eliminated Player, they are Revived by the Catch.